

This factsheet offers insight into various applications of fuel cells for propulsion and auxiliary power in inland ships. Hydrogen storage options and alternative energy carriers are presented with their pros and cons in brief. Information ranges from relevant regulations, technical concepts including benefits and downsides to recommendations for further reading.

FACT SHEET N° 4

FUEL CELL PROPULSION



Picture used with courtesy of © NAVROM

REGULATIONS

The **European committee for drawing up common standards in the field of inland navigation (CESNI)** does not consider the installation of fuel cells in its current regulation **European Standard laying down Technical Requirements for Inland Navigation vessels (ES-TRIN - 2019/1)**.

The **ES-TRIN** requires that all electrical installations on board must be designed for a constant inclination of 15°. In addition, the energy supply must in principle consist of at least two energy sources. If one energy source fails, the remaining energy source must be able to provide the required energy for at least 30 minutes. This means that either the fuel cells have to be divided into (at least) two systems including the fueling system or a battery with sufficient capacity needs to be implemented.

Classification societies like DNV GL already have guidelines for the installation of fuel cells since 2016. The predecessor Germanischer Lloyd has had regulations for the use of fuel cells since 2002 and they were the first classification society to think about this topic.

FUEL CELL FACTS

Fuel cells are energy converters that continuously convert the chemical energy of the fuel, such as hydrogen, (natural) gas or methanol, into electrical energy and thermal energy (heat losses) using an oxidant such as oxygen. The fuel cell can supply electricity as long as suitable fuel is available.

The principle of the fuel cell was invented in 1838, however the first commercial use of fuel cells came more than a century later in NASA space programs to generate power for satellites and space capsules. Since then, the improvement of the fuel cell began and nowadays they are used in many other applications, e. g. for primary and backup power for commercial, industrial and residential buildings and in remote or inaccessible areas. The second most important application for fuel cells is as a power source for vehicles of all kinds.

With fuel cells local emission-free power generation is possible. The comparison of a fuel cell with a conventional internal combustion engine shows that no mechanical stress on components takes place because no fuel is burned. This results in no wear, vibration or generation of noise.

TECHNICAL CONCEPT

The electric motor (1) drives the propeller with constant rpm at any load case. Its advantage is a nearly constant efficiency at all load cases. Depending on the selected electric motor a gear box can be omitted. The frequency converter (2) supplies the electric motor with a frequency and voltage amplitude variable AC voltage. The converter can be supplied by any AC or DC on board energy grid. The rotational speed of the electric motor is controlled by varying the output frequency. The main switch board (3) distributes the energy from all sources to all loads. The loads are frequency converters at the propulsion system. The fuel cell (4) provides the base load. The fuel is stored in the tank (5). Peak loads are absorbed by the battery (6) which can be charged either by the fuel cell or via shore power (7).

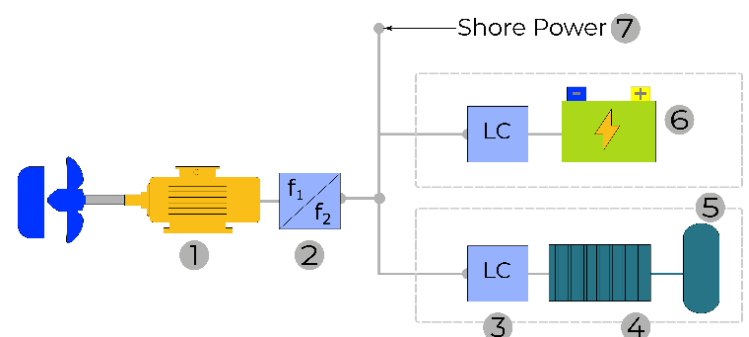

FUEL CELL TYPES

The following diagram shows the basic conversion process in a fuel cell using the example of hydrogen as a fuel.

BASIC WORKING PRINCIPLE OF FUEL CELLS

All fuel cells consist of two electrodes - the anode and the cathode. These are separated by an electrolyte with an ion-permeable membrane. After the fuel has been supplied to the anode, it is divided into electrons and protons. The free electrons flow into an outer circuit between the anode and cathode to be used as an electric current. The protons spread through the electrolyte to the cathode. At the cathode, the oxygen from the air combines with the electrons from the outer circuit and protons from the electrolyte. This results in water and heat.

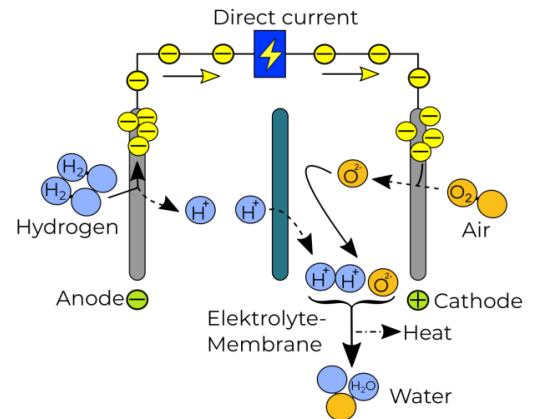

Several fuel cells in a row make up a fuel cell stack. The number of individual cells that are connected in series can be used to variegate the performance of the stack and adapt it to the respective requirements.

All fuel cell types are based on the reaction of a fuel with oxygen. The electrochemical reaction generates basically electricity, heat and water. From the fuel cell, the electricity is provided as direct current (DC). If alternating current (AC) is required for further use, DC from the fuel cell is routed to an inverter is converted there to AC.

CLASSIFICATION OF FUEL CELLS

Basically, fuel cells are classified according to their operating temperature and the type of electrolyte used in the fuel cell. The following fuel cells are particularly interesting for inland waterway vessels:

LOW TEMPERATURE PROTON EXCHANGE MEMBRANE FUEL CELL (LT-PEMFC)

PEMFC uses a water-based polymer membrane as electrolyte, H₂ as fuel and O₂ as oxidant. The operating temperature is < 100°C. Due to the low temperature, only pure hydrogen can be used in PEMFC. The byproducts besides electricity are water and heat. The fuel cell can be started cold without pre-heating to the operating temperature.

HIGH TEMPERATURE PROTON EXCHANGE MEMBRANE FUEL CELL (HT-PEMFC)

If the operating temperature is significantly exceeding than 100°C, PEMFC is used. These can reach up to 200°C and used mineral acid electrolyte instead of a water based one. The fuel cell must first be brought to operating temperature before it functions properly.

SOLID OXIDE FUEL CELL (SOFC)

SOFC contains a solid electrolyte. From an operating temperature of approx. 650°C, this so-called oxide ceramic conducts the hydrogen ions through it. Some devices reach a temperature of 1.000°C. SOFC is one of the high-temperature fuel cells. An internal reforming of natural gas to hydrogen takes place in SOFC itself.

Technology	SOFC	LT-PEMFC	HT-PEMFC
Common size	1kW-10 MW	1-100 kW	< 30 kW
Fuel	Hydrogen, Methanol, Natural gas	Hydrogen	Hydrogen, Methanol, Natural gas
Emission	CO ₂ , low levels of NO _x	-	CO ₂ , low levels of NO _x
Efficiency	60-65 %	50-60 %	50-60 %

All fuel cell systems produce neither SO₂, fine dust particles nor soot. They usually have between 10.000 and 20.000 operating hours, but the fuel cell providers are currently aiming for 30.000h.

ENERGY SOURCES

Various energy sources can be used as fuel for fuel cells. Often hydrogen, methanol or natural gas is used.

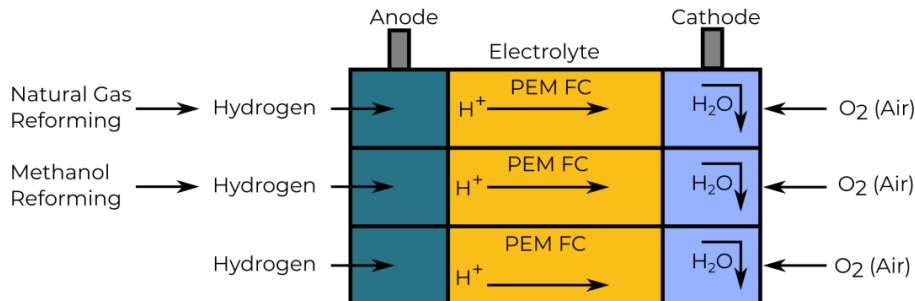

HYDROGEN

Hydrogen (H₂) is gaseous under normal conditions (0°C and 1 bar) with a density of 0.0899 kg/m³. Hydrogen can be transported as compressed gas or liquid and is the most common known chemical element. The most advanced processes for the production of hydrogen are reforming and water electrolysis.

When hydrogen is used in the PEMFC, attention must be paid to hydrogen purity. In principle, any hydrogen contamination can impair the performance and service life of the fuel cell system. The required purity is particularly difficult to achieve during the reforming process from natural gas or methanol. The hydrogen purity should be above 99,99 Vol.-%.

Liquid Organic Hydrogen Carrier (LOHC) is a chemical hydrogen storage. With the help of liquid hydrogen carrier materials, large quantities of hydrogen can be saved, stored and transported without loss and under ambient conditions. The resulting LOHC+ is non-toxic and does not have to be classified as dangerous goods. The existing conventional fuel infrastructure can be used for the transport, whereby no evaporation of stored hydrogen takes place (storage for several months without losses possible). During dehydrogenation a further catalytic reaction takes place, which releases the hydrogen molecules from the carrier liquid. The LOHC-, which is a remaining product, no longer contains hydrogen and must be collected and stored in a separate tank for further use and reloading with hydrogen. The hydrogen can be used as fuel for a fuel cell. The LOHC can bind more hydrogen per litre than the same amount of compressed gas at 700 bar.

METHANOL

Methanol is the simplest member of the group of alcohols with the molecular formula CH₃OH. It is a clear colourless liquid with a density of 0.79 kg/l. It is toxic by ingestion, skin contact or inhalation. Due to the liquid property of methanol (it remains liquid up to a temperature of 60°C), handling is similar to that of diesel or petrol, i. e. storage takes place in simple tanks.

To use the methanol in a PEMFC, the contained hydrogen is separated in a reformer on board. Reforming is the transformation of hydrocarbons, alcohols and other hydrogen-containing compounds into hydrogen.

NATURAL GAS (METHANE)

Natural gas is a combustible, naturally formed gas mixture that comes from fossil sources. Natural gas can be stored and transported in both liquid (LNG) and gaseous (CNG) form. In addition to natural gas from fossil sources, biogenic and even synthetic natural gas can be produced via electrolysis. There are several processes for producing gases with a high artificial methane content.

The individual energy sources that can be used have different energy densities:

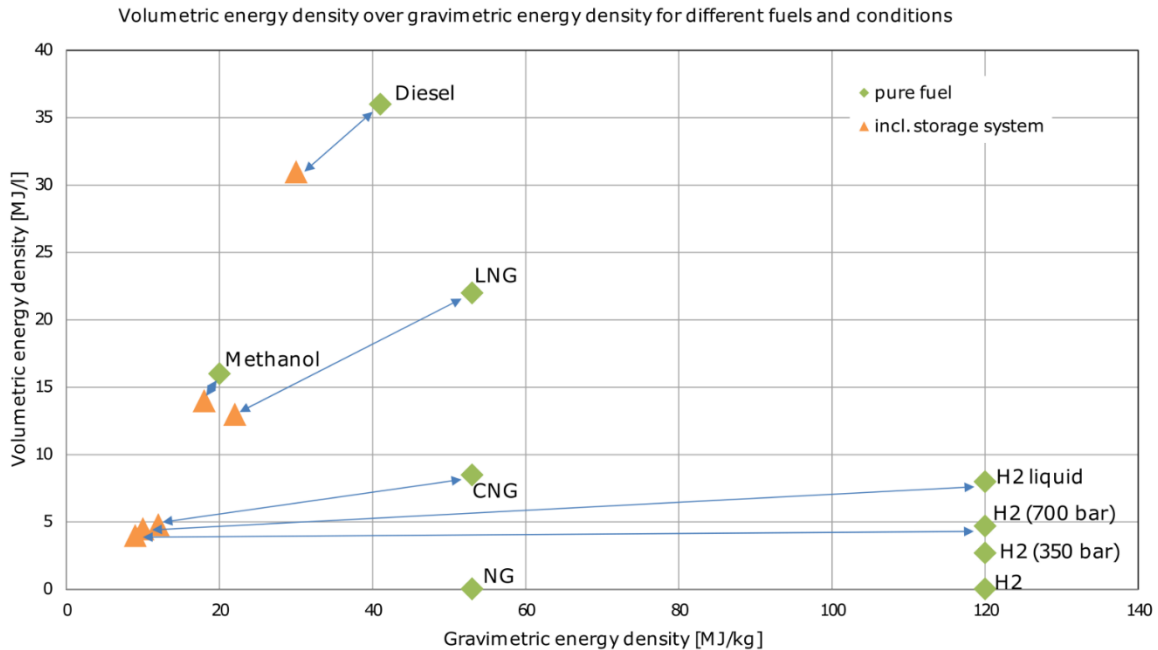

COMPONENTS ON BOARD

The fuel cell system as a propulsion system for a ship often consists of several components. These include the fuel cell, an electric motor, accumulators and partly a reformer. A negative property of the fuel cell is its own inertia to react. This inertia is balanced by an accumulator. It must also be taken into account that a fuel cell needs some time to reach operating temperature, this time difference is also compensated by the accumulator. The fuel cell supplies direct current, the energy produced is transmitted to an electric motor for propulsion. This electric motor, for example, generates the rotary motion for the propeller shaft. The energy requirements for all electrical equipment on board a ship can be supplied directly from the fuel cell or accumulator without detours. The arrangement of the fuel cell and the accumulator can be either parallel or in series.

Methanol system for a HT-PEMFC

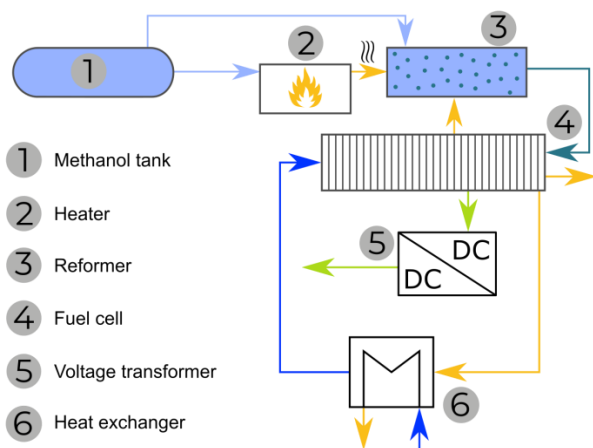

From the methanol tank (1) the fuel is taken to the reformer unit (3) to extract the hydro-gen from it. The process needs heat which is produced by burning an amount of methanol in the heater (2).

The pure Hydrogen is then fed in the fuel cell (5). Some of the reaction heat in the fuel cell is fed back in the reformer. The remaining heat is emitted in a separate heat exchanger system (6).

The voltage of the electric current produced is transformed into the usual on-board voltage by the voltage transformer (5).

Hydrogen system for a HT-PEMFC

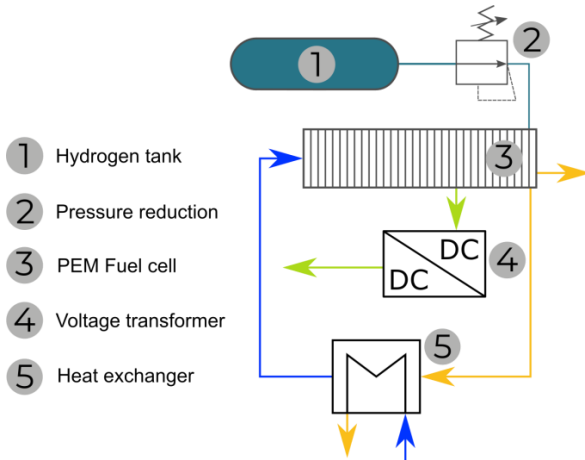

The hydrogen's high pressure in the tank (1) is lowered to a for the fuel cell suitable amount in the pressure reduction unit (2). It is then fed into the fuel cell.

The voltage of the electric current produced is transformed into the usual on-board voltage by the voltage transformer (4).

The reaction heat is emitted in a separate heat exchanger system (5).

INVESTMENT AND OPERATIONAL COSTS

The investment costs as well as the operating costs vary depending on the fuel cell used.

Cost category	Exemplary cost
Hydrogen storage	900 €/kg
LT-PEMFC system	2.000 - 3.000 €/kW
Battery	700 €/kWh
Engine	120 €/kW
Conversion	50.000 €
Hydrogen @ 700 bar	10 €/kg
Methanol	0,30 €/l
Natural Gas H	1,10 €/kg

BENEFITS

- High efficiency at full load and (depending on application) at partial load
- Good controllability
- Good performance extension due to modular design
- Increased comfort (low noise and vibrations)
- Low maintenance
- High development potential

DOWNSIDES

- High investment costs
- Operating experience in field test still low
- Shorter useful life compared to market-dominating products (combustion engine)
- Few suppliers

CONSIDERATIONS FOR DEPLOYMENT

The fuel cell technology is in principle ready for use and represents the ideal energy system depending on the application requirements. The right choice of components can be worked out individually. There are a number of requirements for economic and efficient use:

- Fleet size:
 - Individual deliveries are usually more expensive than mass deliveries
- Infrastructure:
 - If a fuel infrastructure for refuelling already exists, it can usually be used economically
 - If this infrastructure has to be created, its cost-effectiveness must be examined on a case-by-case basis

UPCOMING VESSELS AND PROJECTS

Vessel /Project	Description
MS Antonie	A cargo vessel owned by NPRC shall use hydrogen as fuel. The project partners are NPRC and Nouryon. ⓘ togetherwecandosomuchmore.nl/waterstofschip
Future Proof Shipping	An inland vessel shall be equipped with a hydrogen fuel cell system for propulsion. ⓘ www.futureproofshipping.com
Fuel-Cell Electric energy system for inland navigation and short-sea vessels	A Dutch consortium consisting of Nedstack, MARIN, Damen Shipyards Group, Future Proof Shipping, Marine Service Noord and Holland Ship Electric develops a marinised fuel cell system. ⓘ nedstack.nl/dutch-maritime-consortium-develops-fuel-cell-electric-energy-system-for-inland-navigation-and-short-sea-vessels
FLAGSHIPS project	Development of a fuel cell powered pushboat in Lyon. ⓘ flagships.eu

DEPLOYMENT EXAMPLES

MS INNOGY

Operator: Weisse Flotte Baldeney-GmbH
Location: Germany, Baldeneysee, Ruhr, Rhein-Herne-Kanal
Construction year: 2006
Modification: 2017

① www.baldeneysee.com



Bunker capacity (Methanol): 330 liter
Battery capacity: 2x 60 kWh

Vessel type: excursion boat
ENI: 04804940
Size: 29 × 4.90 m (L × W), Draught: 0.60 m
Propulsion: electric motor 80 kW, reserve diesel engine 182 kW
Fuell cell: 35 kW HT-PEM

FCS ALSTERWASSER

Operator: ATG Alster-Touristik GmbH
Location: Germany, Hamburg, Alster
Construction year: 2008
Decommissioned : 2014

① www.alstertouristik.de

① www.proton-motor.de



Bunker capacity (Hydrogen): 178 liter, tank pressure 350 bar
Battery capacity : 7x 29 kWh

Vessel type: excursion boat – decommissioned
Vessel size: 25,6 × 5,2 m (L × W), Draught (max): 1.33 m
Propulsion: electric motor 100 kW
Fuel cell : 2 × 48 kW PEMFC

NEMO H2

Operator: Rederij Lovers
Location: Netherlands, Amsterdam (canals)
Construction year: 2009
In Operation: 2011

① www.loverson.nl



Fuel cell : 69 kW PEMFC
Bunker capacity (Hydrogen): 1.200 liter, tank pressure 350 bar
Battery capacity : 30-50 kW

Vessel type: excursion boat
ENI: 02333096
Vessel size: 21.95 × 4.25 m (L × W), Draught (max): 1 m
Propulsion: electric bow thruster 11 kW, electric azimuth thruster 75 kW, electric motor 100 kW

Contact

For further information or suggestions how to improve this fact sheet please do not hesitate to contact:

DST – Development Centre for Ship Technology and Transport Systems
 Oststraße 77
 47057 Duisburg, Germany

Phone: +49 203 99369 29
 Fax: +49 203 99369 70
 E-Mail: Friedhoff@dst-org.de
 Web: www.dst-org.de